

40x40x16 SHS  
MIRROR OF DETAIL: 1

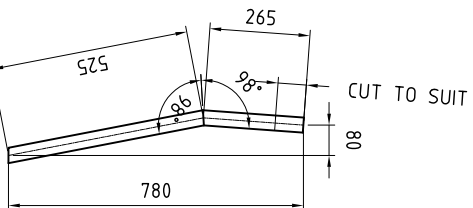

40x40x16 SHS  
MIRROR OF DETAIL: 2



40x40x16 SHS  
MIRROR OF DETAIL: 2



- 1 40x40x16 SHS NOMINAL 1350 LONG CUT TO SUIT 2 PLACE
- 2 25x25x16 SHS NOMINAL 1350 LONG CUT TO SUIT 2 PLACES
- 3 25x25x16 SHS NOMINAL 1400 LONG CUT TO SUIT 2 PLACES
- 4 40x40x16 SHS NOMINAL 1050 LONG CUT TO SUIT 2 PLACES
- 5 DIA 10 BAR 710 LONG 2 PLACES
- 6 40x40x16 SHS (DETAIL 3 AND 4)
- 7 40x40x16 SHS 2 PLACES
- 8 DIA 10 BAR 710 LONG 2 PLACES
- 9 DIA 10 BAR NOMINAL 1250 CUT TO SUIT

- 10 25x25x16 SHS NOMINAL 1000 LONG CUT TO SUIT
- 11 25x25x16 SHS NOMINAL 1350 LONG CUT TO SUIT
- 12 40x40x16 SHS NOMINAL 800 LONG CUT TO SUIT
- 13 40x40x16 SHS NOMINAL 800 LONG CUT TO SUIT
- 14 25x25x16 SHS NOMINAL 1000 LONG CUT TO SUIT 2 PLACES

DETAIL 1

DETAIL 2

DETAIL 3

DETAIL 4

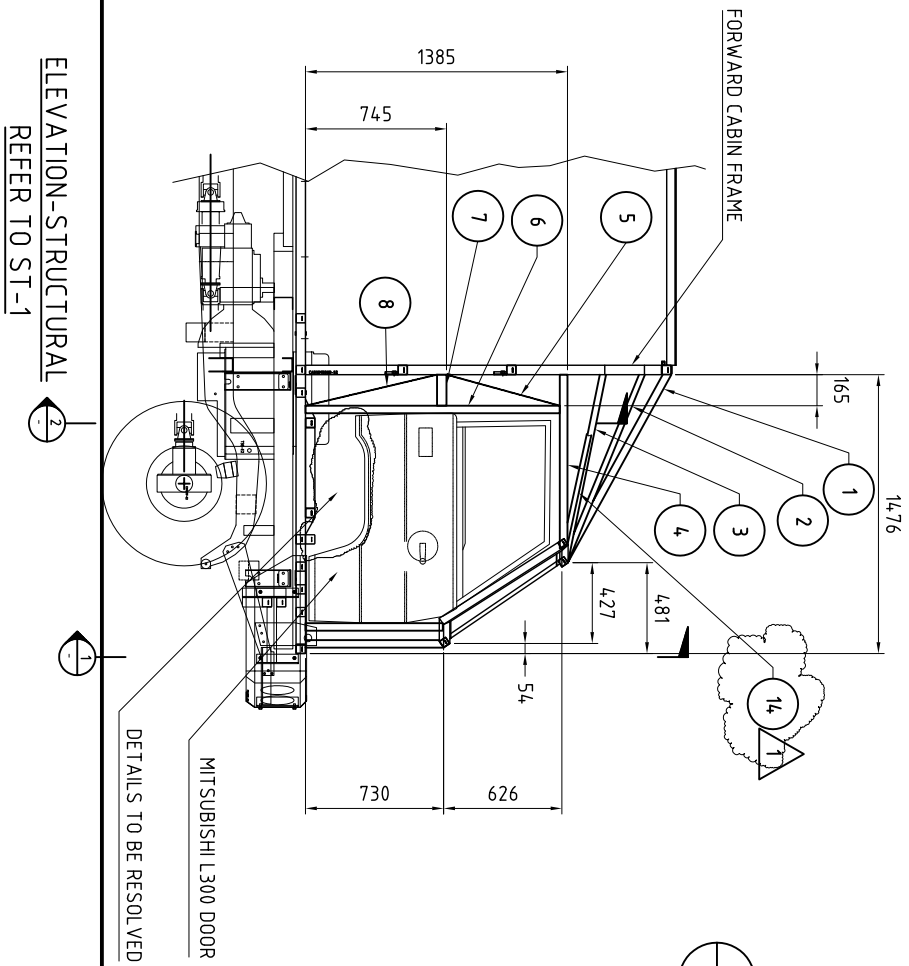

ELEVATION-STRUCTURAL  
REFER TO ST-1

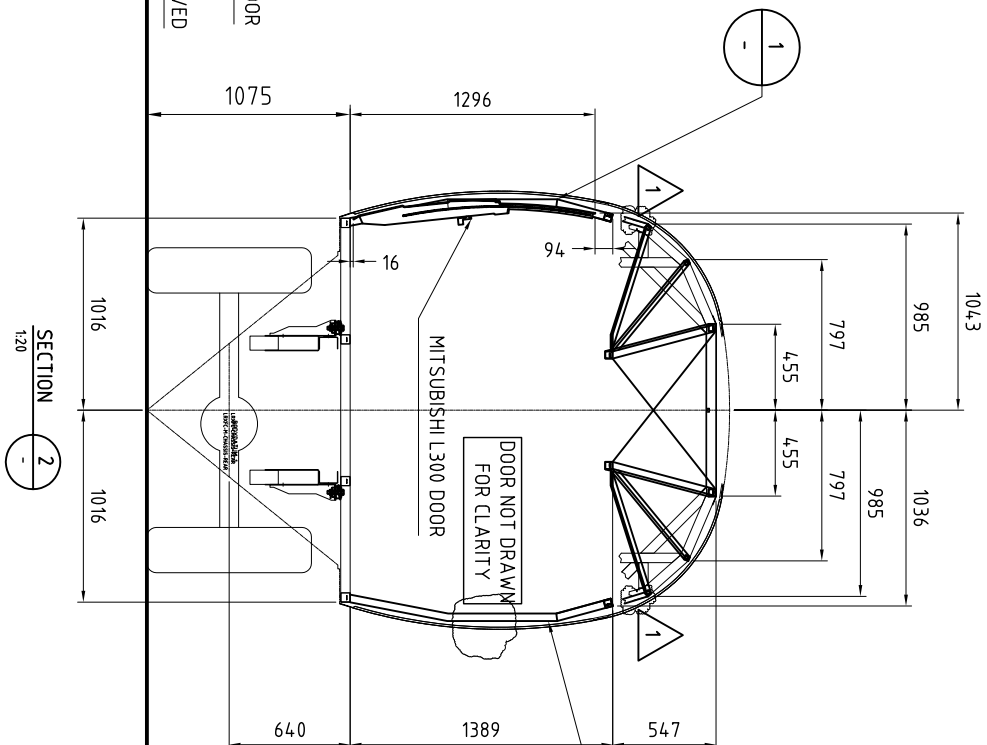

SECTION 2  
1:20

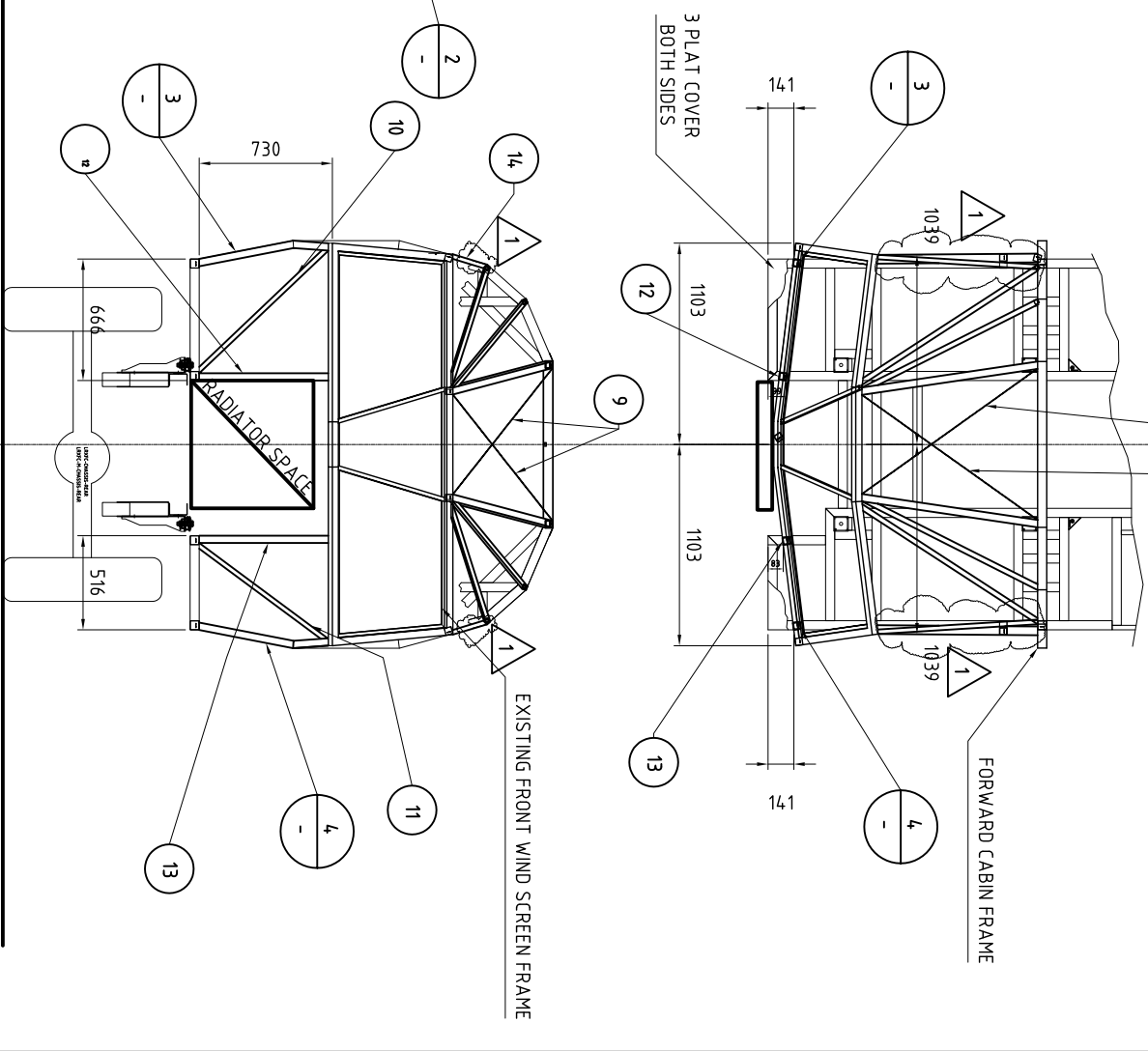

SECTION 1  
1:20

REV.	DATE	DESCRIPTION
1	15/01/07	REVISED DRAWING SCALE AND ADDITIONAL 25 SHS 2 PLACES
0	11/01/07	ISSUED FOR CONSTRUCTION

DRAWING CHECK		CO-ORDINATION CHECK	
SIGNATURE	DATE	SIGNATURE	DATE
DESIGNED (DRG):	15/01/07	STRUCTURAL (RS)	
CHECKED (CHK):	15/01/07	MECHANICAL (RS)	
APPROVED BY (PA):		ELECTRICAL (RS)	
		CIVIL/ENV. (RS)	

MARS SOCIETY AUSTRALIA

STARCHASER MARSUPIAL ROVER  
FRONT CABIN GA

SCALE: 1:20	DIMENSIONS IN MILLIMETRES
CAD FILE NO. & PLOT SCALE	222222...1322
DRG. No.	ST-3
REV.	1